

Universatile™

DIGITAL PANEL METERS

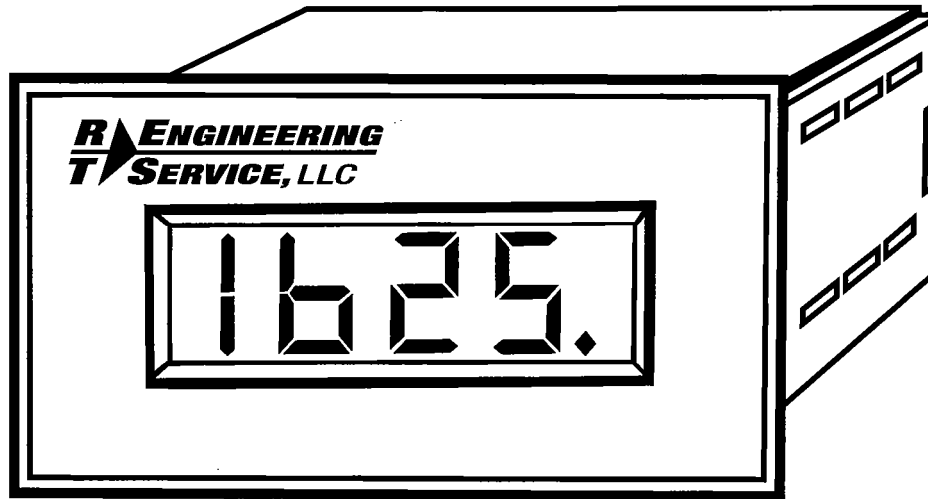

INSTALLATION, WIRING & CALIBRATION

FOR THE

DIN35B & DIN45B

PANEL METERS

R ENGINEERING
T SERVICE, LLC



(800) 343-1182

www.rteng.com

Table of

Contents

SPECIFICATIONS	1
INSTALLATION(A).....	2
WIRING(B).....	2
FIGURE 1(Connection Diagram)	2
CALIBRATION(C)	3
SERVICE NOTES	3
WARRANTY	3
FIGURE 2(Scaling Potentiometer & Decimal Select Pins)	3
DIMENSIONS & CUTOUT REQUIREMENTS	4

SPECIFICATIONS

Typical Signal Inputs	- Process Control Signals 4 - 20 MilliAmp Current 5 - 50 MilliAmp Current 1 - 5 Volt Offset Voltage
Bias Adjustment Range	- 0 - 40% of full scale
Scale Range	- 0 to full scale (0 to 1999 or 0 to 19999)
Accuracy	- .5% linear/1 digit Full Scale
Sample Time	- 3 Updates Per Second
Response Time	- 10 Seconds (Zero to Full Scale)
Power Requirement	- 115 VAC nominal (+ 10V), 50/60 Hz, 2 watts, (230 VAC, 50/60 Hz optional)
Operating Temperature	- +50 Degrees C to -5 Degrees C
Display	- DIN35B, 3.5 Active Digits (000-1999) DIN45B, 4.5 Active Digits (0000-19999) 0.56 inch LED non-blinking. User selectable decimal points at the following positions 1.X.X.X(.X)
Over-range	- Indicated by a "1" in the most significant position with the remaining display blank.
Weight	- 1 pound

**CAUTION: THE COMMON MODE VOLTAGE PRESENT BETWEEN THE INPUT
TERMINALS AND GROUND (CASE) SHOULD NEVER EXCEED 600 VOLTS.**

The R.T. Engineering DIN35B or DIN45B digital panel meter is a versatile instrument designed to fit into a 1/8 DIN cut out. Calibration is performed by using COARSE and FINE potentiometers on the signal input board and will display any 3 1/2 or 4 1/2 digit parameter. User selectable decimal points provide readings from .000/.0000 through 1999./19999.

INSTALLATION AND CALIBRATION

A) Installation:

Remove the front bezel before installation. The bezel is removed by spreading apart the red tabs at the rear of the unit (either side of the terminal strip) and gently pulling the bezel forward. Once the front bezel has been removed simply slide the meter into the 1/8 DIN Cut Out. For new installations refer to **Page 4** which provides mounting dimensions and sizing information. To replace an existing 1/8 DIN panel meter, remove the old unit and insert the new DIN35B or 45B into its place.

The decimal point selection can be performed by adjusting the pin and jumper arrangement at the front of the meter, as shown in **Figure 2**, on page (3).

Note: *When inserted into the mounting hole, the four latching fingers on the case sides should keep the meter firmly in place. Some installations, such as an oversized cut out, non standard panel thickness, extreme vibration, etc., may require mounting brackets which can be ordered separately.*

B) Wiring:

Connect the power input signal of 115VAC (optional 230VAC) to the internally fused 115VAC power input terminals. Determine which current signal you will be working with and if you require the 249 ohm load which is internally connected between terminals 1 and 6. Connect the signal input from its source to the input signal terminals selecting the appropriate range making sure to note the polarity. For best results use shielded cable for signal input. The shield should be connected to the meter common (terminal 1) with the other end floating and insulated. **Figure 1**, below, illustrates the wiring arrangement.

FIGURE 1

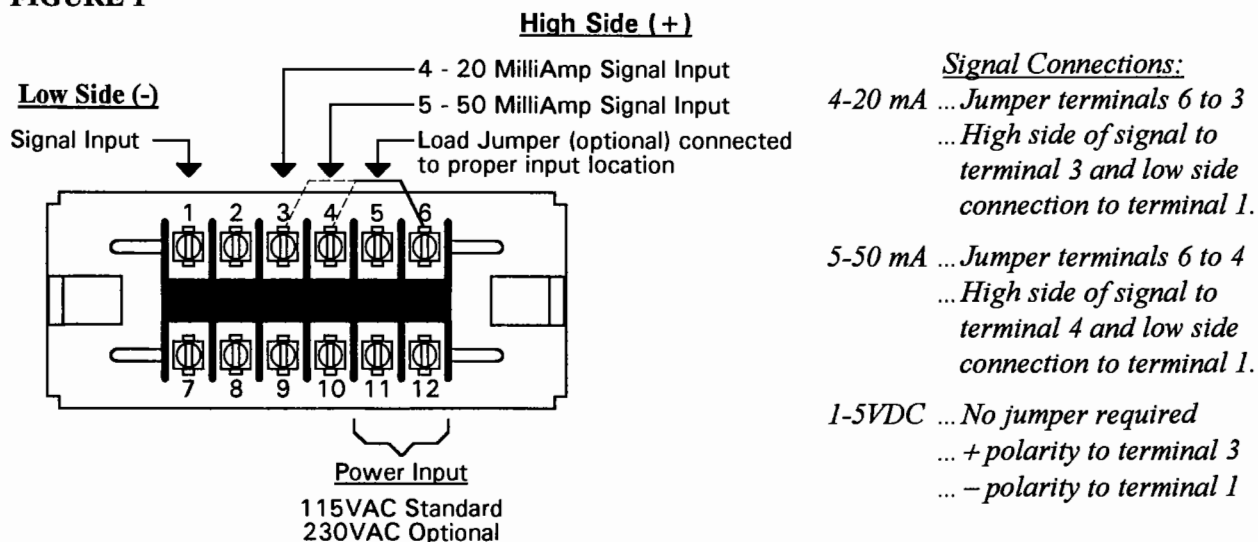

C) Calibration:

Once the unit has been properly installed and wired, activate the meter and apply the maximum signal input to the indicator. Allow the meter about ten minutes to warm up before calibrating.

With the signal source at its minimum input value, use the COARSE BIAS and FINE BIAS adjustment potentiometers to zero the display. Then, with the signal at its maximum value, use the COARSE SCALE and FINE SCALE adjustment potentiometers to adjust the display to the reading you desire. Repeat this procedure.

Check the readings with the signal source at the 25%, 50% and 75% of full scale points. This will confirm how well your measurement system is tracking. After calibration replace the front bezel and the meter is ready for operation.

SERVICE NOTES

A display of 1 in the most significant position followed by a blank display indicates an over scale reading and requires recalibration using the coarse and fine potentiometers or a new range selection (refer to section C).

A display of "000"/"0000" may indicate either reverse polarity or a zero input signal.

As with any piece of electronic equipment, care is recommended when handling and applying voltage. For further information or service contact the factory.

WARRANTY

R.T. Engineering Service, Inc. (RTE) warrants this equipment against defects in material or workmanship for a period of two years from the date of shipment. Material or workmanship defects within the first two years will be repaired or replaced at the option of RTE at no charge. Final determination of the actual defect rests with RTE.

This warranty does not apply to any product which has been misapplied, modified or subjected to misuse, negligence or accident. Any unauthorized repair, service or modification to this equipment voids the warranty.

The foregoing warranty is exclusive and in lieu of all other warranties expressed or implied including but not limited to any warranty of merchantability or fitness for a particular purpose. RTE is not liable for consequential damages of any kind.

Note: Any product found defective should be returned to RTE. The defective meter should be returned freight prepaid by the buyer to RTE.

FIGURE 2

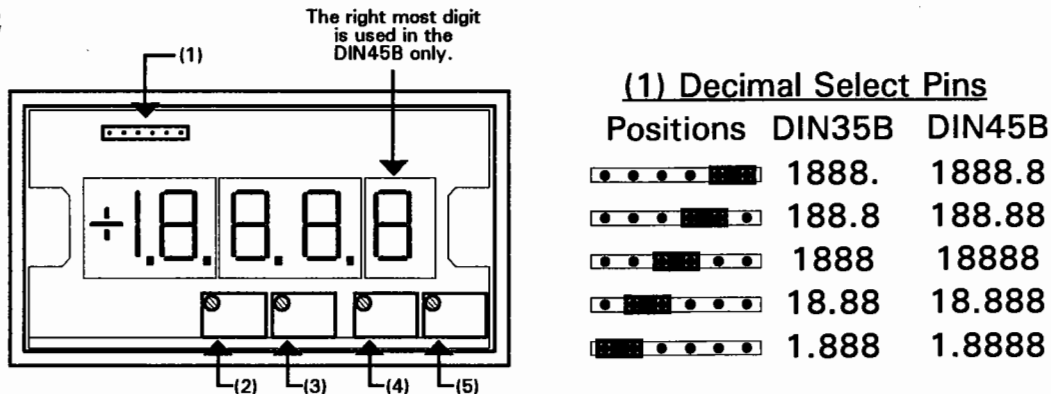

- (2) Multi-turn COARSE SCALE adjustment potentiometer.
- (3) Multi-turn FINE SCALE adjustment potentiometer.
- (4) FINE BIAS adjust.
- (5) COARSE BIAS adjust.

Meter Dimensions and Panel Cutout Requirements

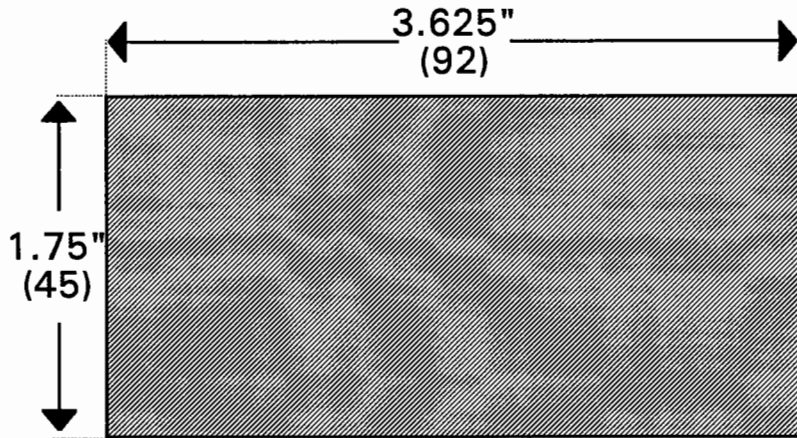

Panel Cutout $\pm 0.005"$ (0.13)

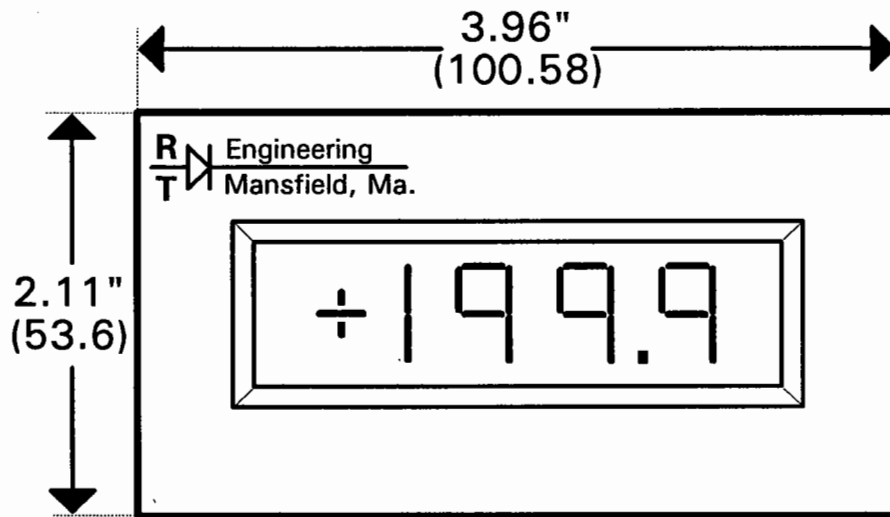

Front View

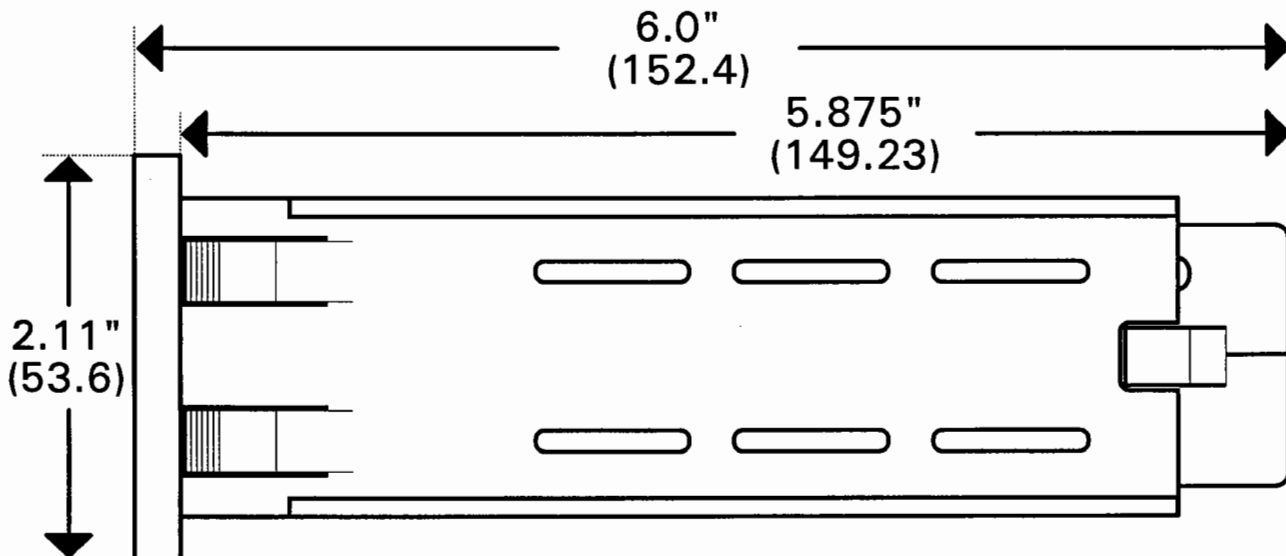

Side View

(4) All Dimensions in Parenthesis () are in Millimeters.