

# Universatile™

## DIGITAL PANEL METERS

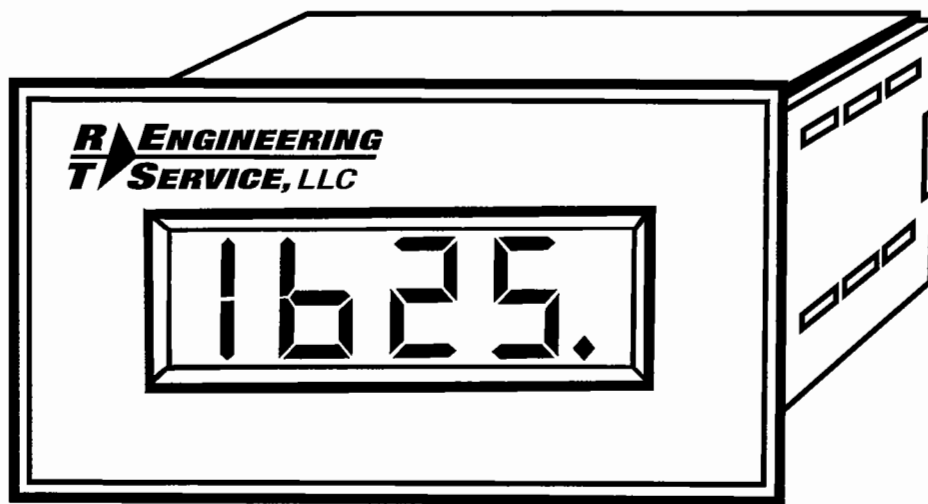

### INSTALLATION, WIRING & CALIBRATION

FOR THE

## DIN35P & DIN45P

### PANEL METERS

**R ENGINEERING**  
**T SERVICE, LLC**



(800) 343-1182

[www.rteng.com](http://www.rteng.com)

## SPECIFICATIONS

Accuracy	- 1% linear $\pm$ 2 digits full scale
Input Signal	- Standard magnetic input (1000 inches per minute maximum) gear or socket speed at 1/64 inch gap - Hall Effect pick-up (5VDC type only at 2 milliamps maximum) zero speed with 1/32 inch gap. ( $\pm$ 5 VDC maximum with respect to common.) Can use R.T. Engineering P/N RT-53Z - Output from either six step or PWM inverter up to 480 VAC when meter has proper interface. Signal Isolation Transformer P/N RT-TA-1-81210 is recommended.
Sampling Time	- 3 readings/second update
Maximum Frequency	- 20,000 pulse per second
Power Requirement	- 115VAC ( $\pm$ 10V), 50/60Hz, 2 watts, (230VAC 50/60Hz optional)
Display	- DIN35P-3 1/2 Active Digits (0 to 1999) - DIN45P-4 1/2 Active Digits (0 to 1999) - .56 inch nonblinking LED. User selectable decimal points at the following positions: 1.x.x.x(.x).
Operating Temperature	- +5°C to +50°C
Overrange	- Flashing Zeros
Weight	- 1 Pound

**NOTE: CAUTION: THE COMMON MODE VOLTAGE PRESENT BETWEEN THE INPUT TERMINALS AND GROUND (CASE) SHOULD NEVER EXCEED 600 VOLTS.**

## CALIBRATION & INSTALLATION

### A. Calibration:

The pulse model is factory set to accept up to 250 pulses per second from a standard magnetic pickup. If this applies to your parameters, go on to the decimal point selection and meter installation section.

To calibrate the meter for a different setting, it is necessary to remove the bezel and case. Spread the red tabs apart and gently pull the bezel away from the meter. Remove the two phillip's head screws at the rear of the meter and slide the printed circuit board (PCB) out of its case.

As shown below, adjust the input selection switch to the appropriate setting.

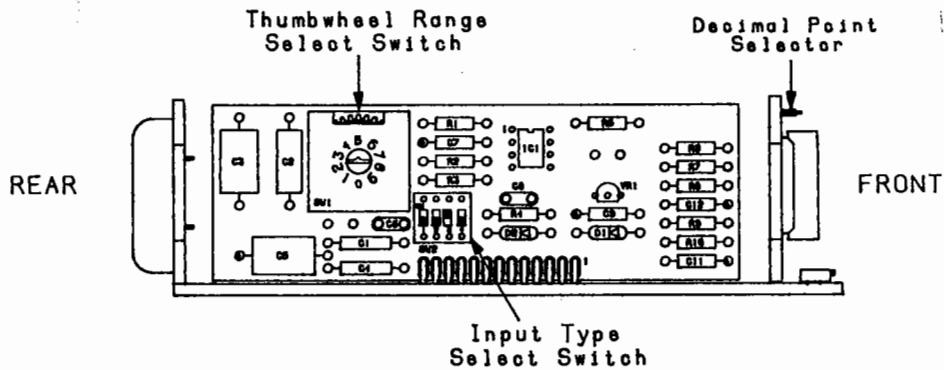

INPUT SETTINGS (SW2)				
	1	2	3	4
STANDARD MAGNETIC INPUT	OFF	OFF	ON	OFF
HALL EFFECT PICK-UP	ON	OFF	OFF	ON
INVERTER	ON	ON	OFF	ON

Refer to Figures one and two and determine the range selection required. Adjust the thumbwheel switch to the correct setting.

## B. Decimal Point Selection:

At the front of the meter, as shown in Figure three, the decimal point selection can be performed by adjusting the pin and jumper arrangement.

NOTE:           Decimal point selection should only be performed when the meter has been powered off.

## C. Installation:

To replace an existing 1/8 DIN panel meter, remove the old unit and insert the new DIN35 or 45 into its place. Make sure the bezel has been removed before installing the device.

For a new installation refer to figure four, which provides mounting dimensions and sizing information.

NOTE:           When inserted into the mounting hole the four latching fingers on the case sides should keep the meter firmly in place. Some installations, such as an oversized cutout, nonstandard panel thickness, extreme vibration, etc., may require mounting brackets which can be ordered separately.

## WIRING

Once the meter has been calibrated, refer to the appropriate wiring diagram for your application.

	<u>Figure</u>
Standard Magnetic Pickup	5
Hall Effect Pickup	6
Variable Frequency Output from an Inverter	7

**Pulse Model:** Standard and Hall Effect Magnetic Pickup.

Wire the meter as illustrated in figure five or six and mount the sensing head on the magnetic pickup between 1/64 and 1/32 inches from the face of the gear teeth. The tip of the sensor must have a smaller diameter than the distance between the gear teeth.

Run the machine at maximum speed and adjust the coarse and fine potentiometers to the desired engineering units. **See figure three.**

### **Inverter Output Model:**

Wire the meter as illustrated in figure seven to the isolation transformer (Part Number RT-TA181210) and then to the output of the inverter.

**WARNING:** The isolation transformer should be used in all applications. Failure to do so may cause damage to the variable speed controller.

Run the inverter at maximum speed and adjust the coarse and fine potentiometers to the desired engineering units. See figure three.

If the display is to be calibrated for frequency, temporary jumper connections may be made between the 115VAC supply terminals and the signal input terminals. Adjust the meter to display 60.0 (60.00). Remove the jumpers and reconnect the signal input terminals.

### **D. Service Notes:**

1. A display of flashing zeroes indicates an overscale reading and requires recalibration using the coarse and fine potentiometers or a new range selection (refer to the calibration section).
2. The indicator installed, wired and powered with no input signal should read zero plus or minus one count. If this is not the case, remove the input signal leads and install a short jumper between the input signal terminals. Check for a zero reading. If a zero is now displayed, a "noise signal" is being induced through the signal input cable. This can be corrected with shielded cable.

Low voltage signals or signals referencing feedback from a drive should use shielded cable to minimize noise interference. The shield should be connected to the meter common (+ input) with the other end floating and insulated.

If a zero reading is still not obtained with the input shorted, adjust the zero potentiometer as shown in figure three.

If the above procedures do not work, please contact the factory.

3. As with any piece of electronic equipment, care is recommended when handling and applying voltages. For further information or service contact the factory.

### **E. Warranty:**

R.T. Engineering Service, LLC (RTE) warrants this equipment against defects in material or workmanship for a period of two years from the date of shipment. Material or workmanship defects within the first two years will be repaired or replaced at the option of RTE at no charge. Final determination of the actual defect rests with RTE.

This warranty does not apply to any product which has been misapplied, modified or subjected to misuse, negligence or accident. Any unauthorized repair, service or modification to this equipment voids the warranty.

The foregoing warranty is exclusive and in lieu of all other warranties expressed or implied, including, but not limited to any warranty of merchantability or of fitness for a particular purpose. R.T. Engineering shall not be liable for consequential damages of any kind.

Any product found defective should be returned to RTE. The defective meter should be returned freight prepaid by the buyer to RTE, marked attention: Warranty Returns

R. T. Engineering Service, LLC  
1 Merchant Street, Suite L1  
Sharon, MA 02067  
Tel. (800) 343-1182  
Fax (617) 784-3296

# TYPICAL FREQUENCY VS. DISPLAY CURVES

FREQUENCY IN PULSES PER SECOND (PPS)

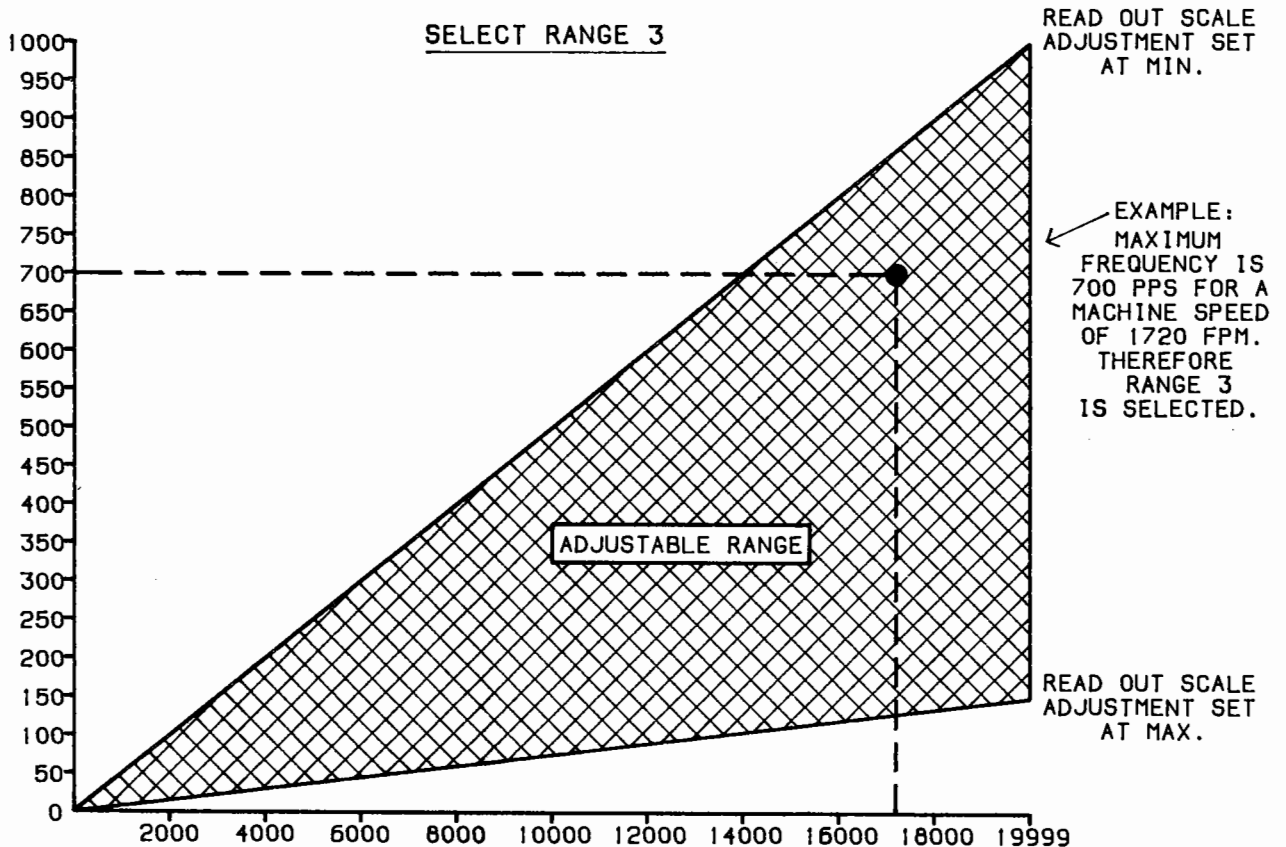
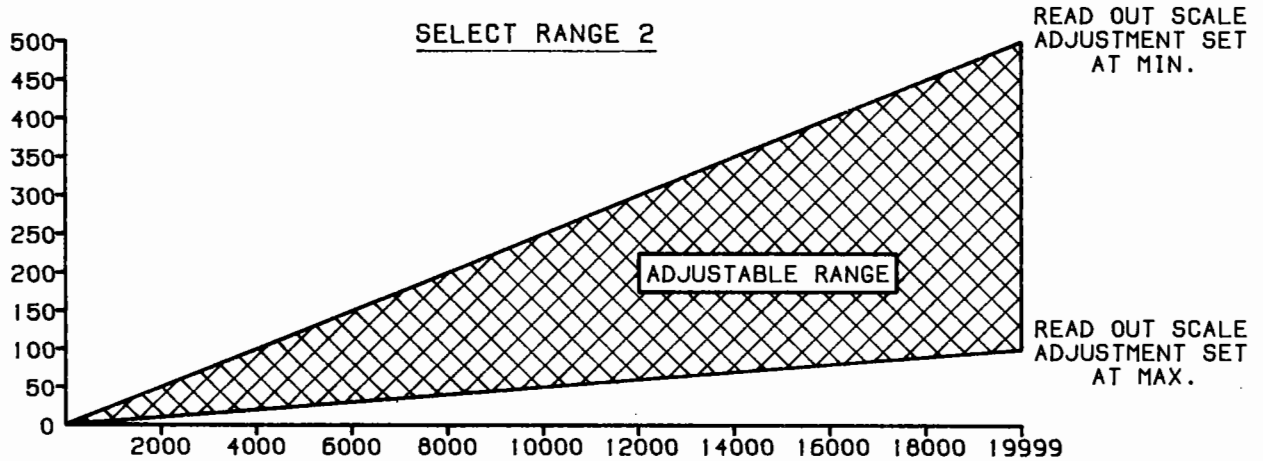
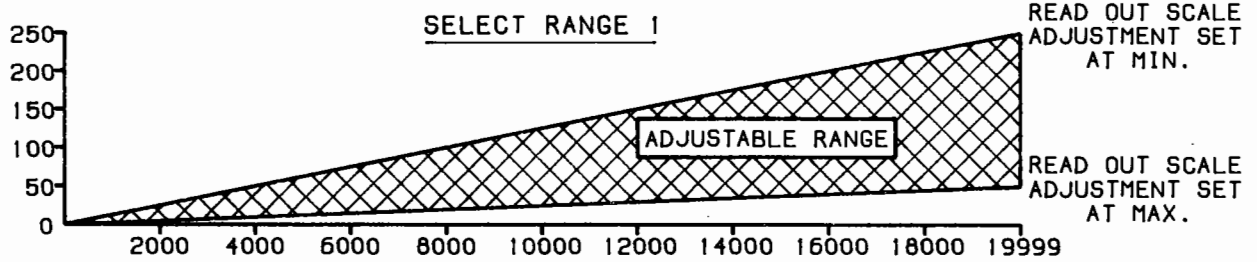

READ OUT DISPLAY

Figure 1

# TYPICAL FREQUENCY VS. DISPLAY CURVES

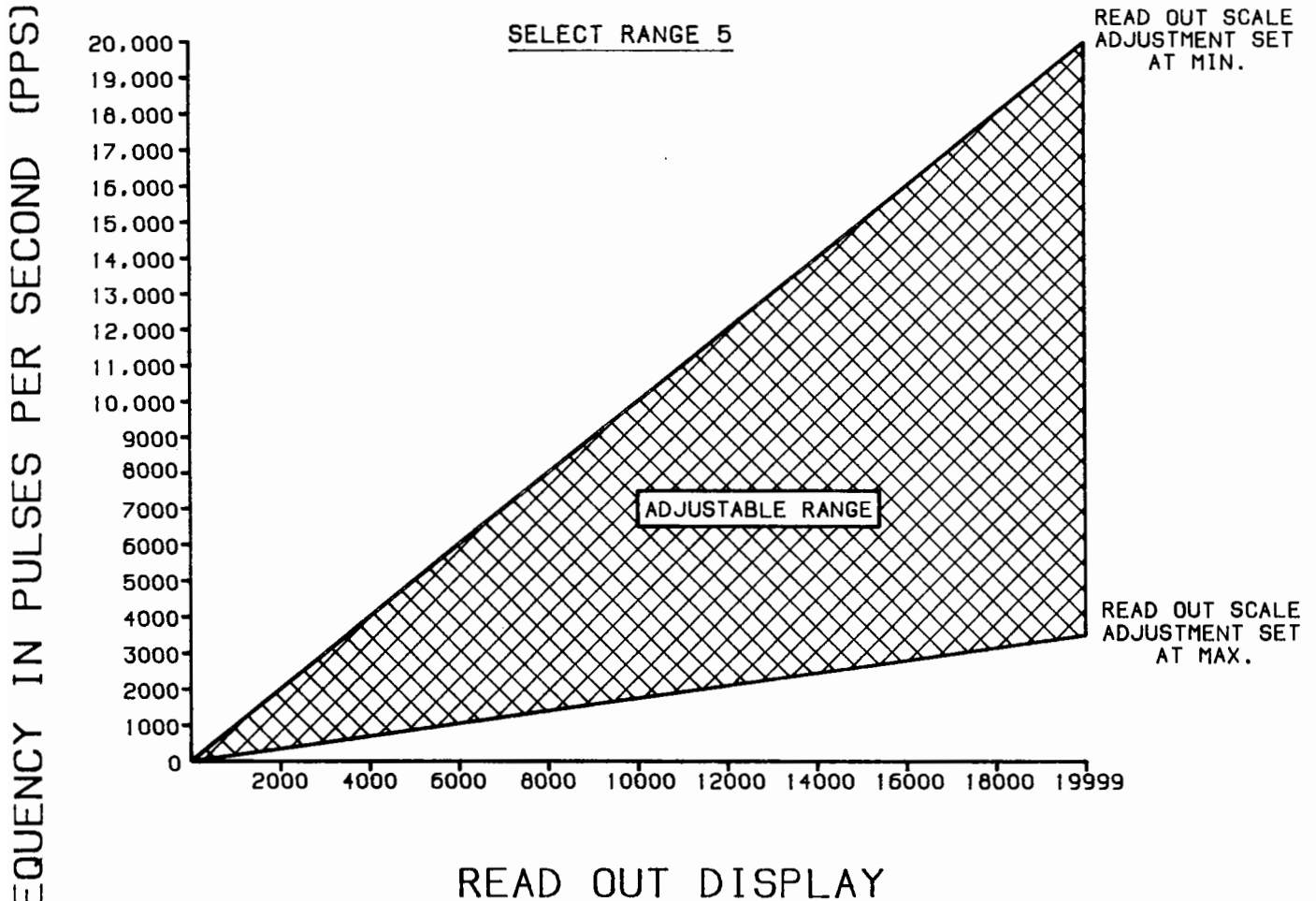
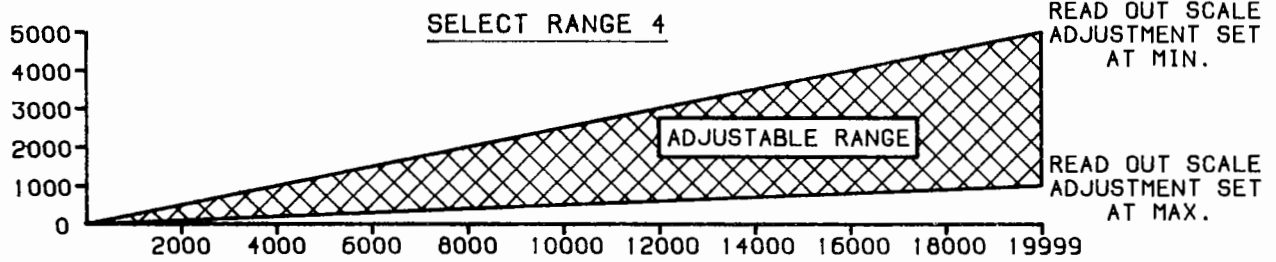

$$\text{MAX. FREQUENCY} = \frac{(\text{NO. OF GEAR TEETH}) (\text{MAXIMUM RPM})}{60}$$

EXAMPLE:

$$\text{MAX. FREQ.} = \frac{(60 \text{ TEETH}) (1750)}{60}$$

$$\text{MAX. FREQ.} = 1750 \text{ PPS}$$

Figure 2

# DECIMAL POINT SELECTION & INDICATOR CALIBRATION

## DECIMAL POSITIONS

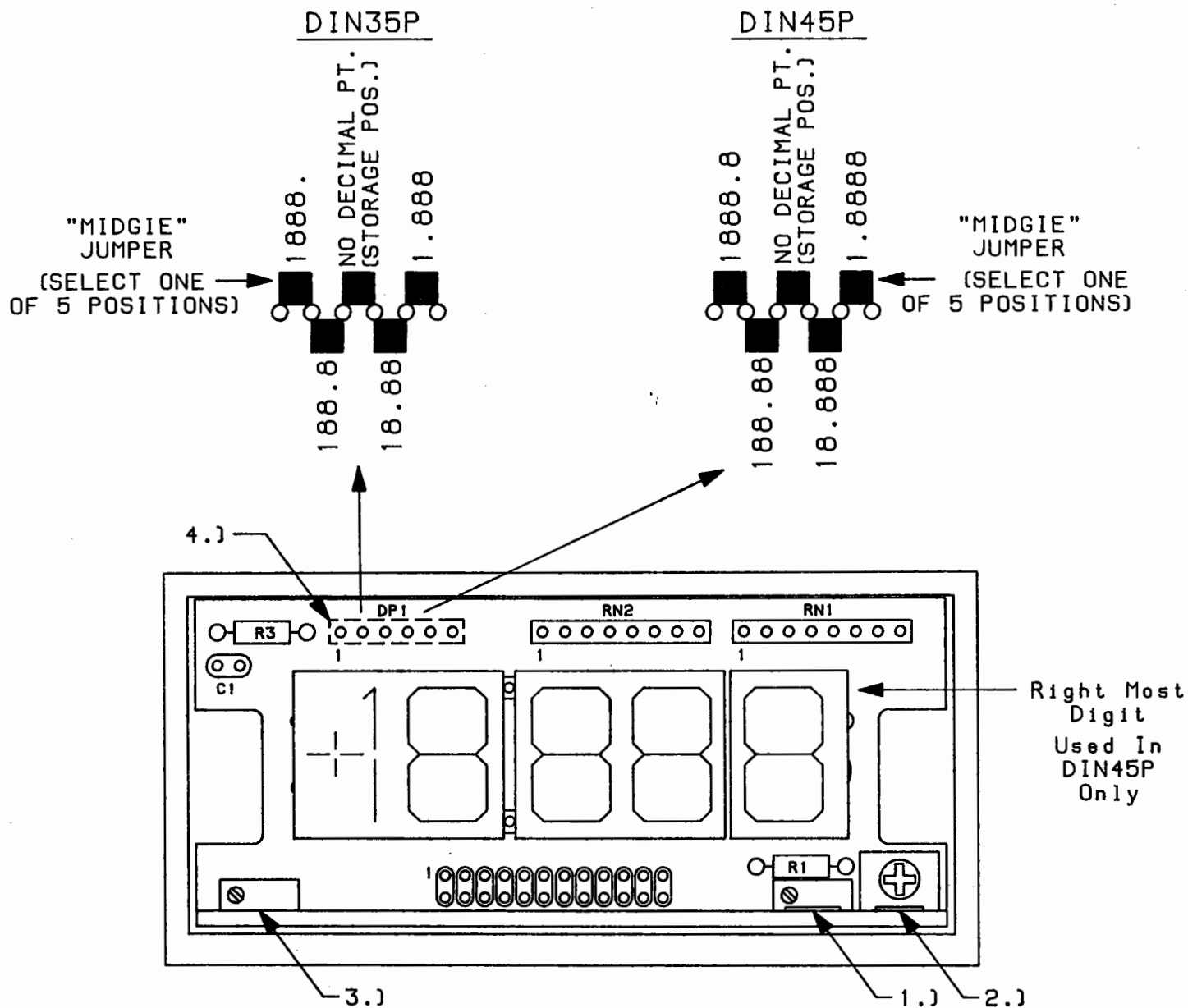

FRONT OF METER WITH LEXAN BEZEL REMOVED.

- 1.) Multi-turn "course" scale adjustment potentiometer.
- 2.) Multi-turn "fine" scale adjustment potentiometer.
- 3.) Zero Potentiometer.
- 4.) Decimal Select Pins.

Figure 3

# Panel Cutout Requirements

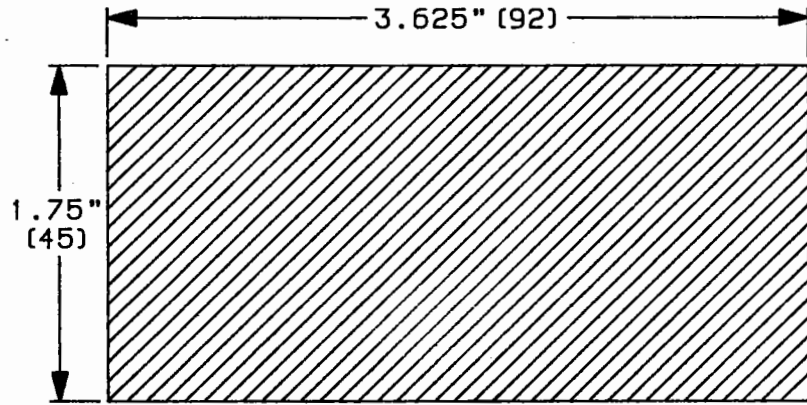

Panel Cutout  $\pm .005$  (172)

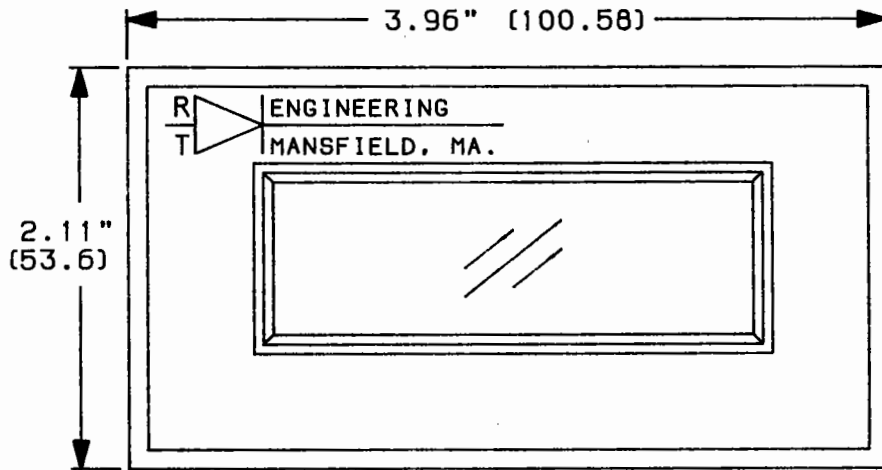

Front View

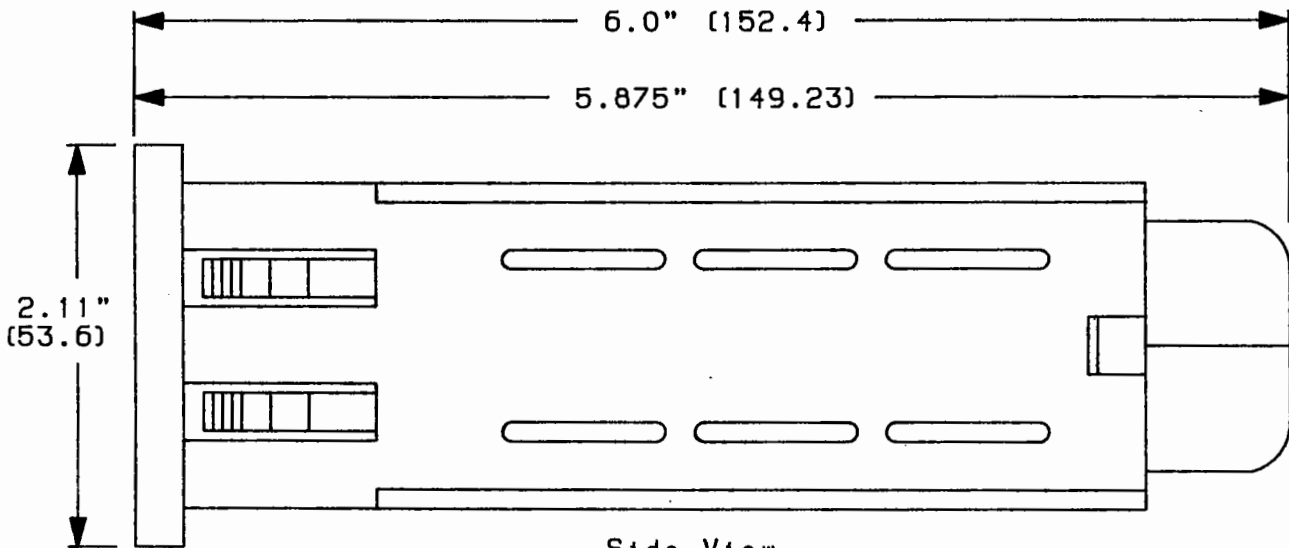

Side View

All Dimension in Parentheses ( ) are in Millimeters.

Figure 4

# TERMINAL FUNCTIONS FOR DIN35P & DIN45P

## "STANDARD MAGNETIC PICK-UP"

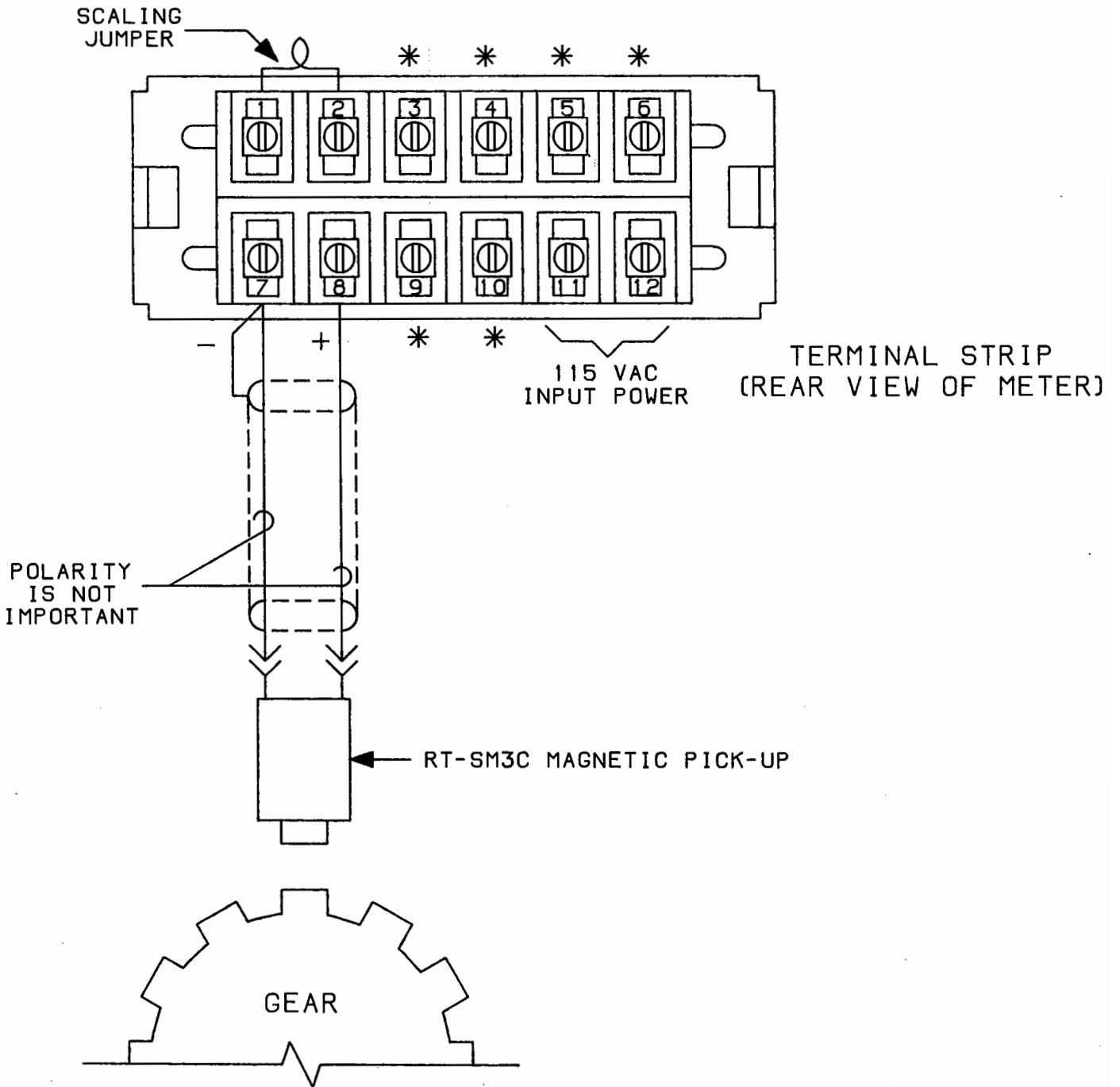

NOTES: RUN SIGNAL TO METER THROUGH SHIELDED CABLE, GROUNDING ONE END OF SHIELD AS SHOWN. THE PICK-UP END OF THE SHIELD SHOULD BE LEFT LOOSE AND WRAPPED WITH ELECTRICAL TAPE.

\* - DENOTES TERMINAL NOT USED.

Figure 5

# TERMINAL FUNCTIONS FOR DIN35P & DIN45P

## "SLOW SPEED HALL EFFECT PICK-UP"

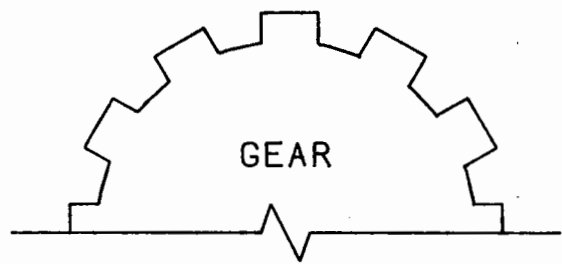
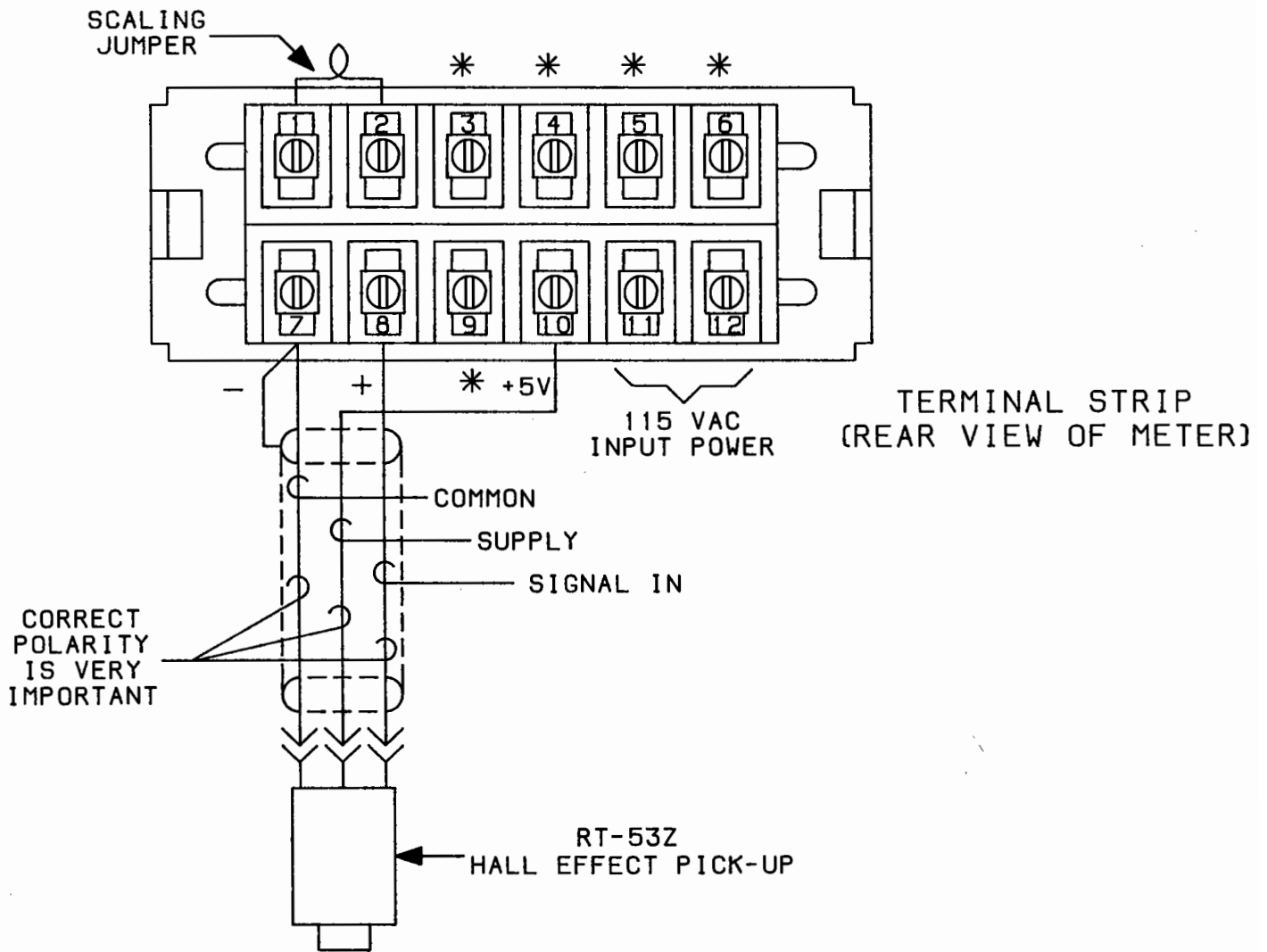

### PICK-UP CONFIGURATION

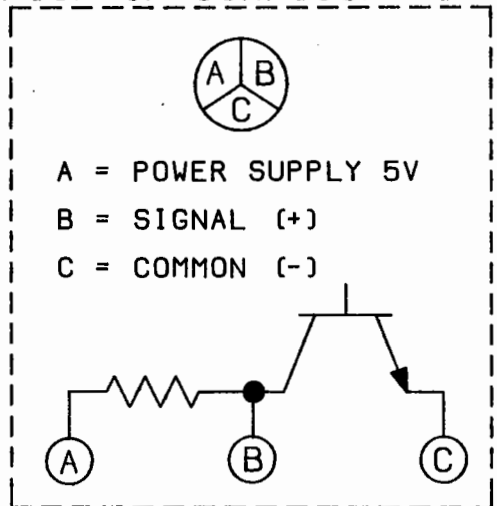

NOTES: RUN SIGNAL TO METER THROUGH SHIELDED CABLE, GROUNDING ONE END OF SHIELD AS SHOWN. THE PICK-UP END OF THE SHIELD SHOULD BE LEFT LOOSE AND WRAPPED WITH ELECTRICAL TAPE.

\* - DENOTES TERMINAL NOT USED.

Figure 6

# TERMINAL FUNCTIONS FOR DIN35P & DIN45P

## "CONNECTION TO INVERTER"

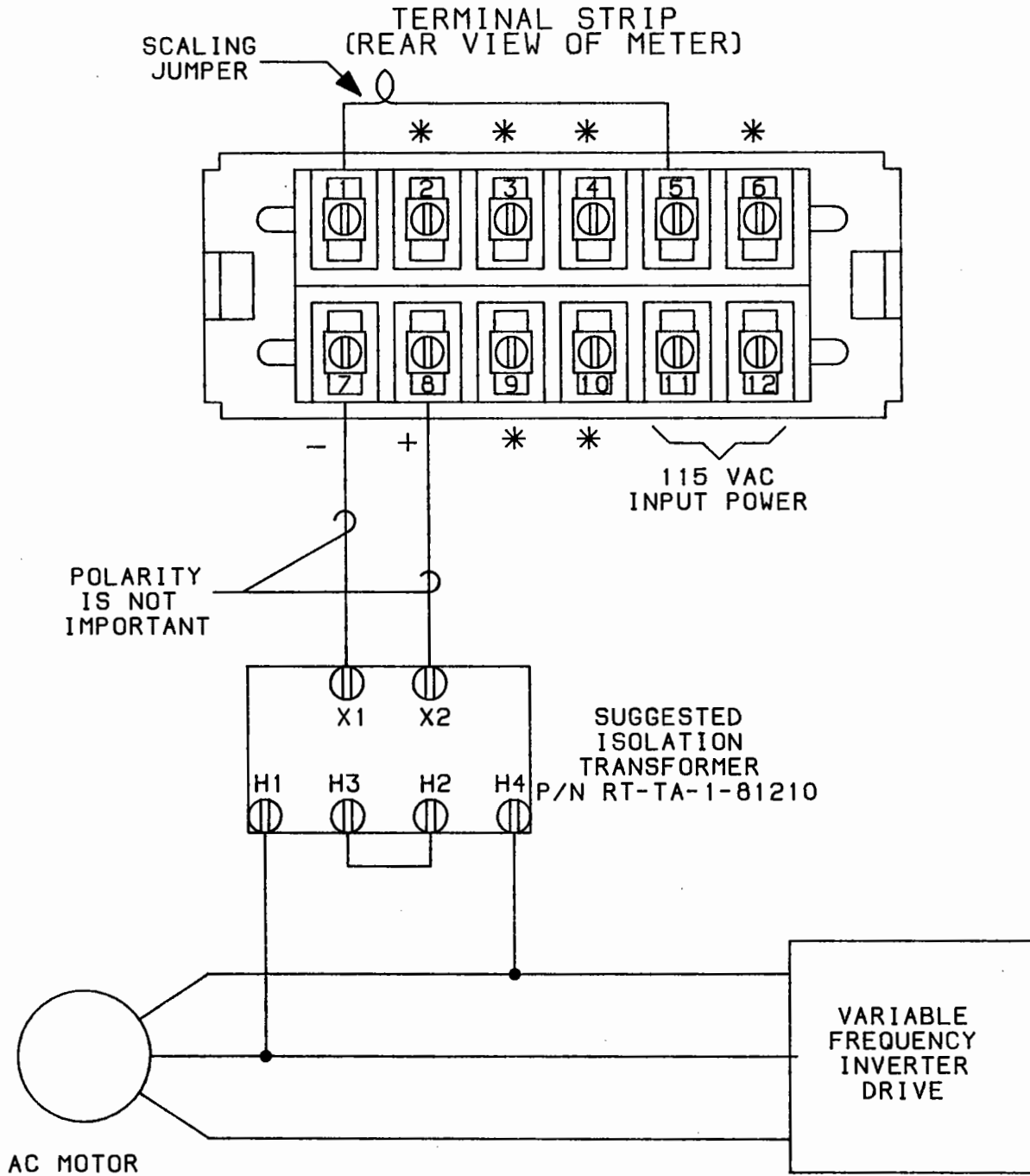

\* - DENOTES TERMINAL NOT USED.

Figure 7