

Universatile™

DIGITAL PANEL METERS

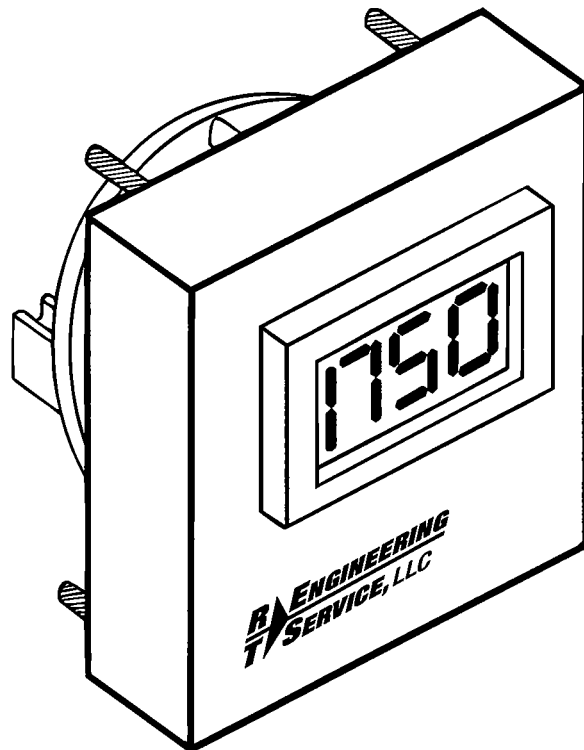

INSTALLATION, WIRING & CALIBRATION

FOR THE

DPM35B/L

PANEL METERS

R ENGINEERING
T SERVICE, LLC



(800) 343-1182

www.rteng.com

The R.T. Engineering series DPM-35MRL-B Panel Meter is a uniquely versatile instrument. It is designed to fit in the same mounting cutout as a standard 4 1/2" Analog Meter, yet will accept a wide range of voltage and current inputs from a wide variety of input signal devices. The unit can be very simply calibrated, via two (2) twenty-five turn pots in the rear, to read out any 3 1/2 digit parameter required from .000 to 1999, with a bias capacity of 0 to 1000. The units have user selectable decimal points at three locations.

The DPM-35MRL-B has four input voltage ranges within which it can handle input signal levels of 50mvDC/100mvAC (F.S.) to 500VDC/480VAC (F.S.) and milliamps inputs of 4-20ma or 5-50ma.

The level at which the solid state relay contacts are set to close, is easily adjusted via a 25-turn pot underneath the display bezel. Once set, the relay contacts will close when the display value becomes lower than or equal to the value which was set. A LED will blink on and off and is visible through the display bezel. If desired, an audible alarm can be made to sound when the contacts become closed. If desired, it can be made to silence itself after 30 seconds.

SPECIFICATIONS

Input Ranges	- (A) 50 millivolts DC (100 Millivolts AC) - (B) 5 VDC (10 VAC) - (C) 50 VDC (100 VAC) - (D) 500 VDC (480 VAC)
Bias range	- 0 to 1000
Scale range	- 0 to full scale (1999) A shunt resistor must be added for current measurement, 50 ohms to 600 ohms inclusive.
Maximum Input & Overvoltage	- 1000% of range or 500 VDC (480 VAC) whichever is less
Accuracy	- .5% linear +1 digit full scale
Input Resistance at Nominal Scale Values	
Voltage input	- 20K Ohms/Volt D.C. 9K Ohms/Volt A.C.

- Current input - Equals resistance of shunt being utilized
- A.C. Frequency Range
 - Maximum signal frequency - 2KHz
 - Maximum signal frequency - 40Hz - extends down to 2 Hz for readings of 010 or below (A.C. tachometers)
- Sampling Time - 3 readings/second update
- Response (000 to 1999) - 6.5 seconds
- Power requirement - 115 VAC nominal (+10V), 50/60 Hz, 2 watts, (230 VAC, 50/60 Hz optional)
- Operating temperature - 5 C. to 50 C.
- Relay Contacts
 - Type - Solid State N.O.
 - Rating - 115VAC 50/60Hz, .5 Amps (500 Milliamps)
- Trip Level Accuracy - 0.1% of Full Scale
- Typical Signal Inputs - A.C. or D.C. Signals from : Line Voltage, Reference Voltage, Tachometers, Force Transducers (Load Cells), Shunt, Current Transformers, Pressure & Flow Transducers
- Display - 3 1/2 active digit (0-1999). 0.5 inch LED nonblinking. Optional decimal points at the following positions: X.X.X.X
- Overrange - Indication by a "1" in the most significant position with remaining display unit.
- Weight - 1 Pound

CAUTION: The common mode voltage between the input terminals and ground (case) should never exceed 600 volts.

INSTALLATION AND CALIBRATION

A) Installation

If the meter is to replace an existing 4 1/2" panel meter, all that should be required is to pull out the old meter and insert the DPM-35MRL-B in its place. If the meter being replaced has non-standard dimensions, or if the DPM-35MRL-B is a new meter addition, see the attached layout for proper cut-out dimensions. Insert meter in cut-outs and tighten retaining nuts.

B) Wiring

Connect 115VAC power to "115 VAC" terminals. Meter is internally fused. Connect input signal from source to terminals marked "input" if input is a D.C. signal note polarity connection.* Low voltage signals relating to a reference or feedback for a drive system should be run in shielded cable to minimize any noise pickup from the cable run. The shield should be connected to meter common (+ input). The other end of the shield should be floating and insulated via electrical tape or other means. For a milliamp input a shunt resistor (50 ohms to 600 ohms, 1/2 watt) must be placed in parallel with the input terminals. Care must be taken to properly connect the polarity of the input to the indicated terminals.

*Although this unit has been tested for peak operational voltage insulation integrity both between input terminals and input to case, we recommend that on input voltages greater than 200 volts RMS a 100K ohm, 1/2 watt metal film resistor be placed in series with each leg of the input signal wires. This is solely for the protection of the signal device in the event of a fault to ground or short within the meter itself.

C) Calibration

1. Calibration Procedure for Milliamp Inputs

As shipped the range selection jumper is installed on the "B" scale which will accommodate milliamp inputs. The meter is also shipped with a burden resistor installed across the signal input terminals for milliamp applications.

There are two adjustments through which the meter is calibrated. These are 1. Bias, 2. Readout Scale. The setting of these are as follows (with the burden resistor in place).

Step 1. Apply input of 4 ma.

Step 2. Set the readout for the desired value (0 to 1000) by the bias potentiometer.

Step 3. Apply input of 20 ma.

Step 4. Set the readout for the desired value by adjusting the readout scale potentiometer

Step 5. Repeat steps 1 through 4 until the desired readouts are achieved. This is due to the interaction of the two adjustments.

2. Calibration Procedure for Voltage Offset Applications

The DPM-35MRL-B can be utilized as an offset meter where a readout of from 0 to 1000 is desired when the input signal equals zero, and the display is linear from the preloaded offset value up to full scale (1999). For this application the burden resistor across the input terminals is not required. Care must be taken in selecting the proper jumper range. The meter is shipped with the jumper on scale "B", this is the normal range for milliamp inputs. For a voltage input the jumper position must be determined by the method below.

Method I

Install jumper (J1) on the range scale "D". Apply maximum signal and adjust the "readout scale" potentiometer located on the back of the meter until the approximate desired readout is obtained. If this readout cannot be obtained remove the signal input and move the jumper (J1) down on range to scale "C". Reapply input signal again adjusting the "readout scale" potentiometer to the desired readout. If necessary repeat above on the next lower range scale until desired readout is obtained.

After the proper scale selections have been chosen the offset and final calibration can be made through these two adjustments
1. Bias, 2. Readout Scale.

The setting of these adjustments is done as follows (use of burden resistor is not required).

- Step 1. Apply zero or lowest input signal.
- Step 2. Set the readout for the desired offset value (0 to 1000) by adjusting the Bias potentiometer.
- Step 3. Apply maximum input.
- Step 4. Set the readout for the desired value by adjusting the "readout scale" potentiometer.
- Step 5. Repeat steps 1 through 4 until the desired parameters are achieved.

NOTE: Several adjustments may be required before the desired readouts are achieved. This is due to the interaction of the two adjustments.

Set the decimal point select switch on the back of the meter for the desired decimal point placement.

D) Setting Meter Relay

This adjustment should be made only after you have calibrated the meter. Refer to diagram "B". Remove the red plastic bezel. This can be easily pried off with your fingers. Set SW1 1 and 2 to on (↑). The red trip light will come on. Using a small screwdriver, adjust the "trip" adjustment until the display reads the number you want the meter to trip at. Set SW1 1 and 2 to off (↓). The meter is now set to operate.

When the display reads the same number, or lower than the number you have set, the relay contacts will close. The red trip light will come on and blink to show that the meter is being tripped. The contacts will remain closed until the display value again becomes greater than the number you have set.

Refer to Diagram "B". If SW1-4 is on (↑), an audible alarm will sound as the meter goes below set point. If SW1-3 is on (↑) the alarm will be on as long as the meter stays below set point, but if SW1-3 is off (↓) then the meter will automatically silence itself after 30 seconds.

NOTE: Setting the trip level adjustment does not in any way affect the calibration of the meter.

The internally fused solid state relay contacts located on the back of the meter are rated at 115 VAC, 50/60 Hz @ .5 Amps (500 milliamps). If the device you wish to have the meter relay control requires more current, or is D.C. voltage or any voltage other than 115 VAC, 50/60 Hz, an external relay having a coil rating of 115 VAC, 50/60 Hz must be used.

E) Service Notes:

1. A display of 1 on the left hand digit followed by a unlit display indicates an overscale reading and requires recalibration using the "readout scale" adjustment and/or a new range selection (refer to Section C).
2. With the indicator installed, wired, power applied and with no signal input, the display should read zero plus or minus a count. If this is not the case, remove the signal input leads and install a short jumper between the signal input terminals and check for zero readings as above. If zero is now obtained, this indicates a "noise signal" is being induced in the signal input cable. This can be corrected with shielded cable (see wiring notes on page 3, section B. If a zero reading cannot be obtained with the input shorted, please consult the factory).
3. A display of "000" may indicate reversed polarity of the input signal or a zero input signal.
4. The input signal stage of the meter will accept a voltage up to 10 times the rated value for a given range or 500 volts whichever is less. (eg. range "B" is rated 5 VDC, 10 VAC and will accept up to 50 VDC, 100 VAC).
5. As with any given piece of electronic equipment, care is recommended in handling and applying voltages. For further information or service contact:

R.T. Engineering Service, Inc.
P.O. Box 520
65 Maple Street
Mansfield, Ma. 02048

1-800-372-2123 (Ma.)

1-800-343-1182 (Outside Ma.)

WARRANTY

R. T. Engineering Service, LLC (R.T.E.) warrants this equipment against defects in materials or workmanship for a period of two (2) years from date of shipment.

Standard products manufactured by R.T.E. are warranted to be free from defects in workmanship and material for a period of two years from date of shipment, and products which are defective in workmanship or material will be repaired or replaced, at the option of R.T.E., at no charge to the buyer. Final determination as to whether a product is actually defective rests with R.T.E.

Any product found to be defective should be returned, transportation prepaid by buyer, to R.T.E at the above address. This warranty will not apply to any product which has been subjected to misuse, negligence, or accident; or misapplied; or modified or repaired by unauthorized persons; or improperly installed. R.T.E. cannot assume responsibility or accept invoices for unauthorized repairs to its components, even though defective. Any modification made internal or external to the meter may void this warranty as will opening the meter enclosure.

The foregoing warranty is exclusive and in lieu of all other warranties expressed or implied, including but not limited to any warranty of merchantability or of fitness for a particular purpose. R. T. Engineering shall not be liable for consequential damages of any kind.

The aforementioned provisions do not extend the original warranty period of any article which has been either repaired or replaced by R. T. Engineering.

DIAGRAM "A"

(REAR OF METER)

DPM-MR-B

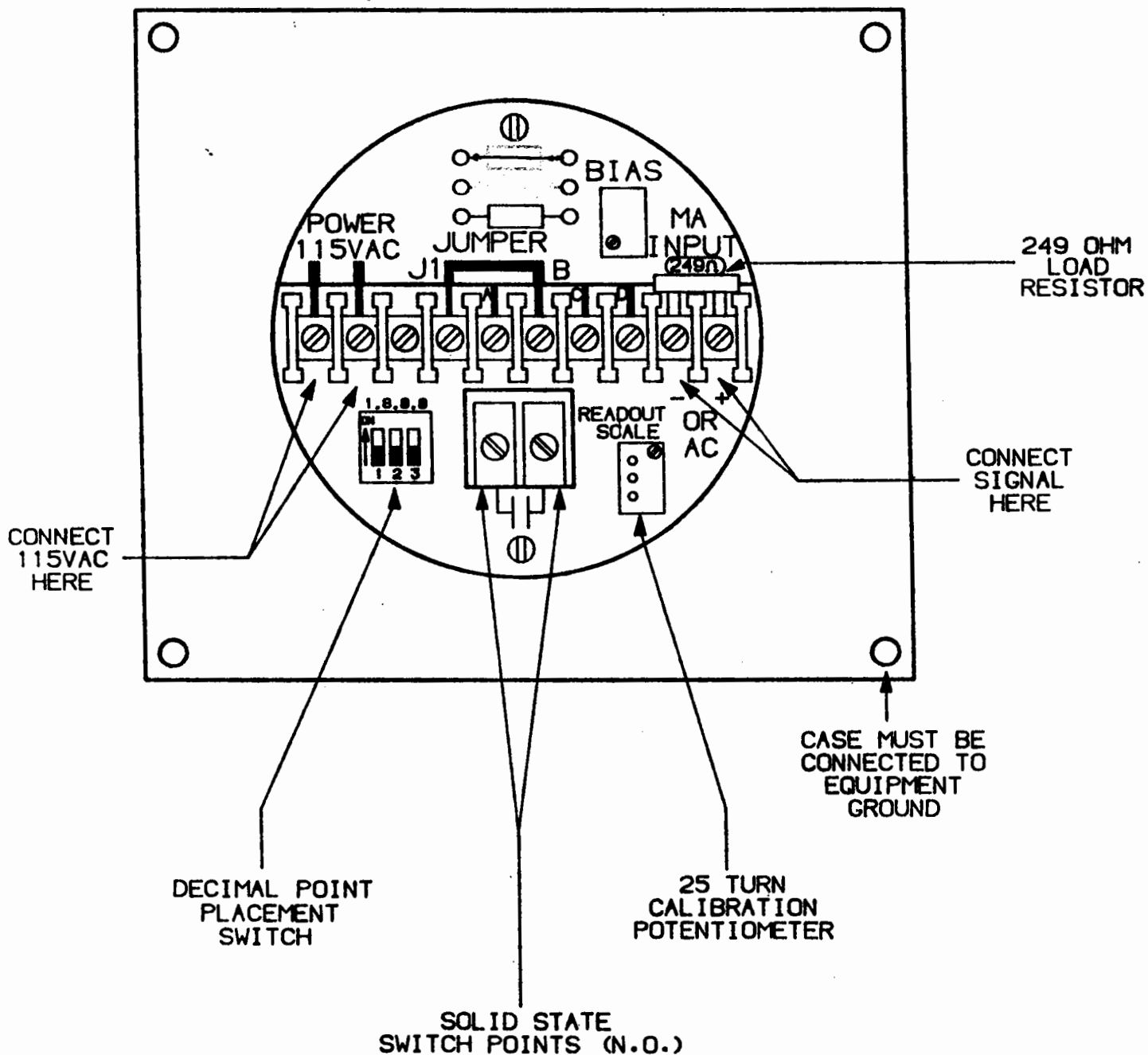
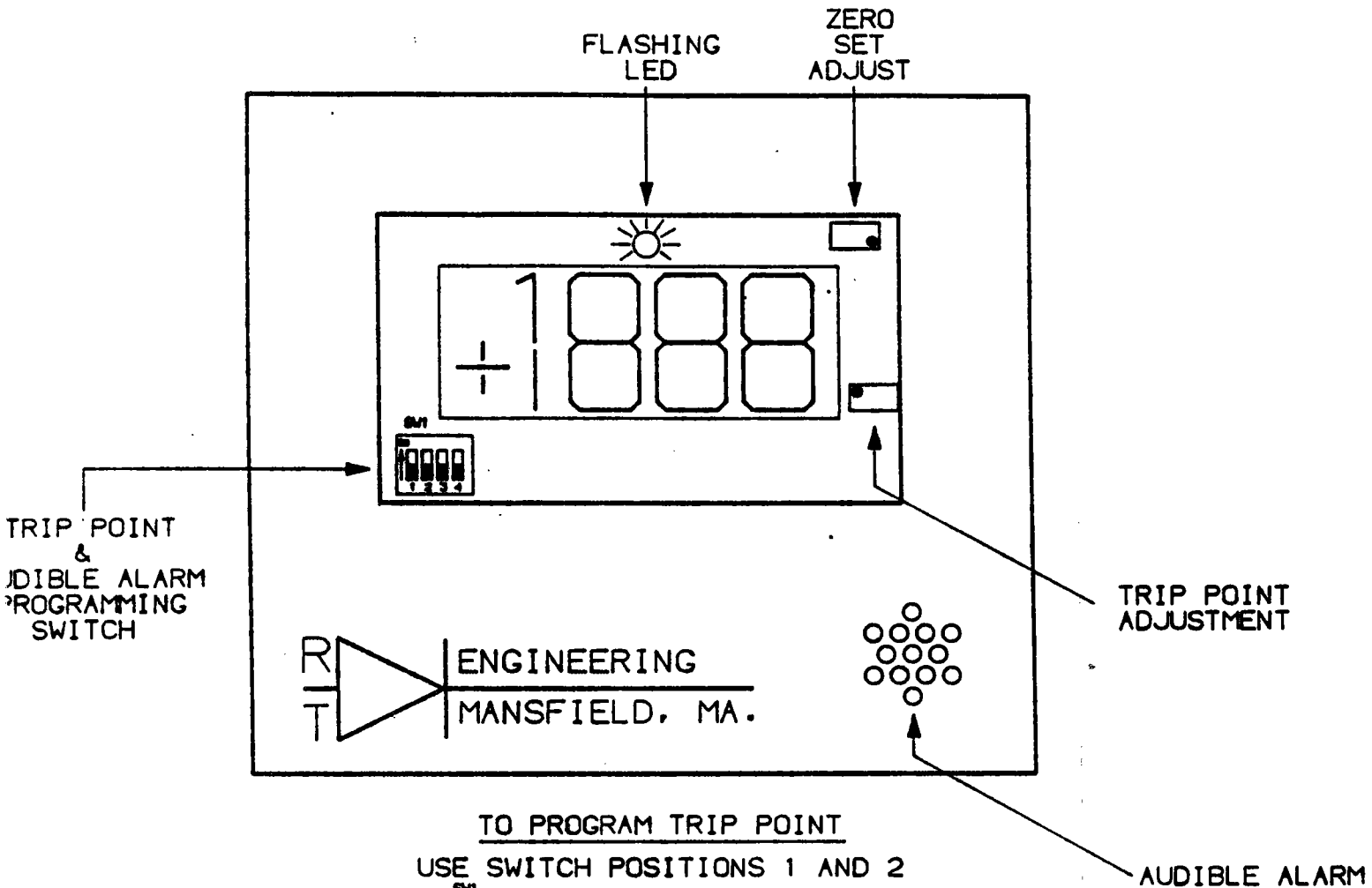

DIAGRAM "B"

(FRONT OF METER)



TO PROGRAM TRIP POINT

USE SWITCH POSITIONS 1 AND 2



TO PROGRAM AUDIBLE ALARM

USE SWITCH POSITIONS 3 AND 4

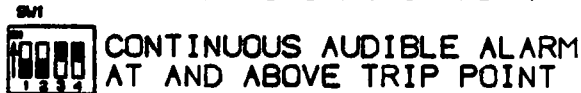

MOUNTING LAYOUT

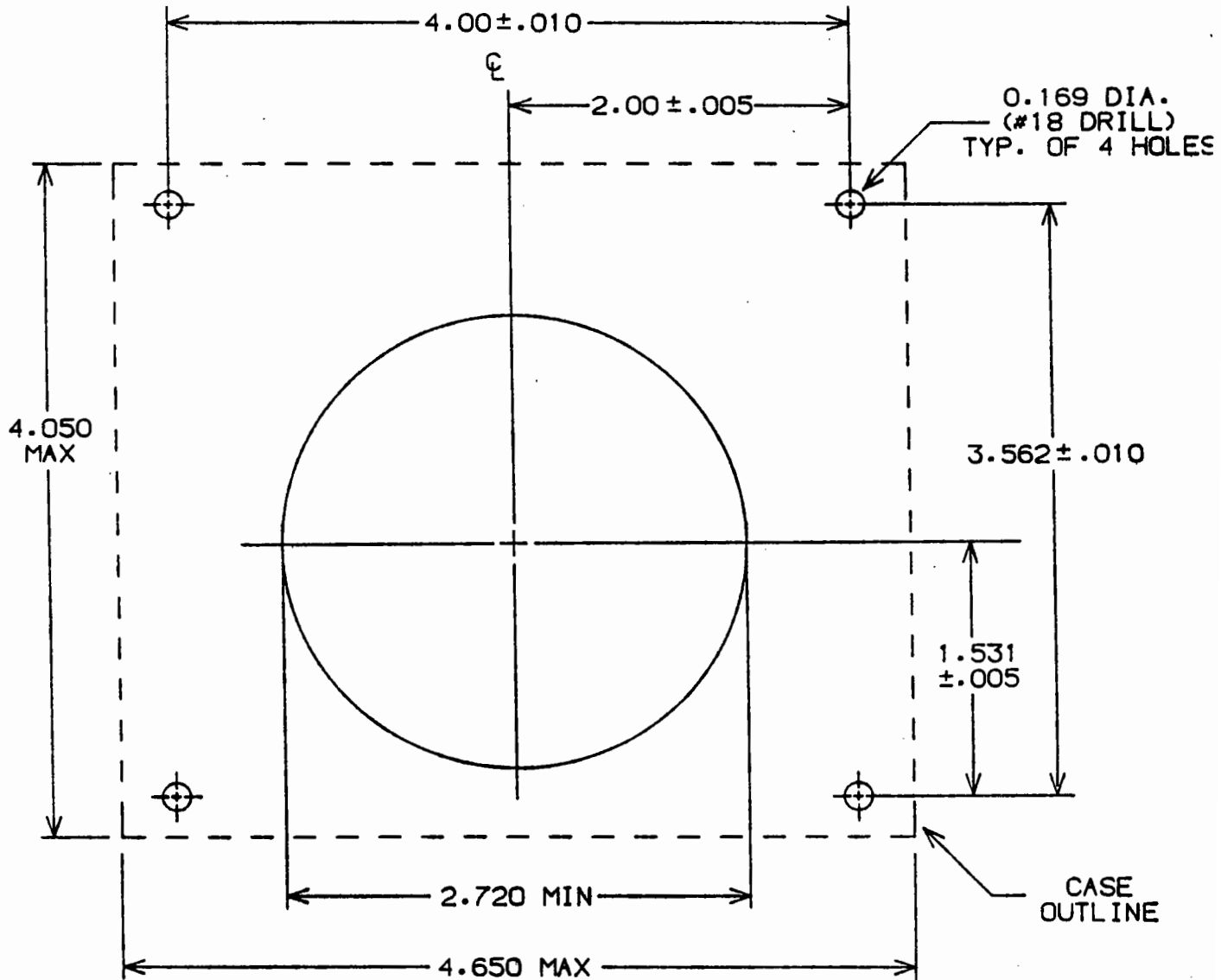

NOTES:

- 1) ALL DIMENSIONS ARE IN INCHES.
- 2) TOLERANCE ON FRACTIONAL DIMENSIONS IS $\pm 1/32$.
- 3) THIS IS NOT A TEMPLATE.