

Universatile™

DIGITAL PANEL METERS

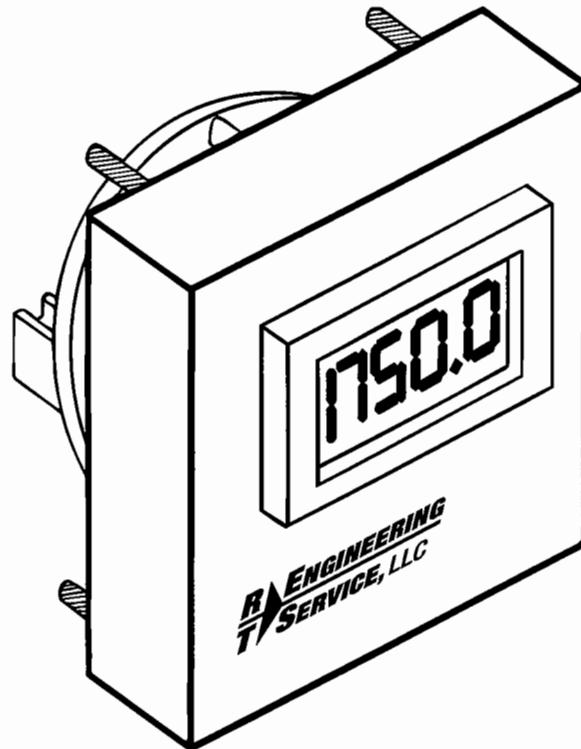

INSTALLATION, WIRING & CALIBRATION

FOR THE

DPM45

PANEL METERS

R ENGINEERING
T SERVICE, LLC



(800) 343-1182

www.rteng.com

Contents

SPECIFICATIONS	1
INSTALLATION(A).....	2
WIRING(B).....	2
CALIBRATION(C)	2
SERVICE NOTES	3
WARRANTY	3
FIGURE 1(Connection Diagram).....	4
FIGURE 2(Dimensions).....	5
FIGURE 3(Frontal Layout & Decimal Selector)	5

SPECIFICATIONS

Input Ranges	- (A) 50mVDC: 100mVAC - (B) 5VDC: 10VAC - (C) 50VDC: 100VAC - (D) 500VDC: 480VAC
Maximum Input & Overvoltage	- 1000% of range or 500VDC (480VAC) whichever is less
Accuracy	- .5% linear ± 1 digit F.S.
Input Resistance at Nominal Scale Values	- 20K Ohms / Volt D.C. 9K Ohms / Volt A.C.
A.C. Voltage Measurements Maximum Signal Frequency	- 2KHz
Minimum Input Frequency	- 40Hz
Sampling Time	- 3 Readings / Second Update
Response (000 to 1999)	- 6.5 Seconds
Power Requirement	- 115VAC Nominal ($\pm 10V$), 50/60Hz, 2 Watts, (230VAC, 50/60Hz Optional)
Operating Temperature	- 5 Degrees C to 50 Degrees C
Typical Signal Inputs	- A.C. or D.C. Signals from : Line Voltage, Reference Voltage, Tachometers, Force Transducers (Load Cells), Shunts, Current Transformers, Pressure & Flow Transducers
Display	- 4 1/2 Active Digits (0-19999) with 0.56 inch non-blinking LEDs. Optional decimal points at the following positions: 1.X.X.X.X.(user selectable)
Over-range	- Indicated by flashing zeros in the display
Weight	- 1 pound

CAUTION: THE COMMON MODE VOLTAGE PRESENT BETWEEN THE INPUT TERMINALS AND GROUND (CASE) SHOULD NEVER EXCEED 600 VOLTS.

The R.T. Engineering DPM45 digital panel meter is a versatile instrument designed to fit into the same mounting cutout as a standard 4 1/2" analog meter. This device will accept a wide range of voltage inputs from a variety of input signal devices. Calibration is performed using the coarse and fine potentiometers on the signal input board and will display any 4 1/2 digit parameter. The display uses selectable decimal points to provide readings from .0000 through 19999.

The DPM45 has four voltage ranges which can accommodate input signal levels of 50mVDC / 100mVAC (F.S.) to 500VDC / 480VAC (F.S.).

INSTALLATION AND CALIBRATION

A) Installation:

If this unit replaces an existing 4 1/2" panel meter, remove the old meter and insert the new DPM45 in its place. See **Figure 2** for cutout dimensions when replacing a non-standard device or making a new meter installation. Once the meter has been inserted into the panel tighten the retaining nuts.

B) Wiring:

Connect 115VAC power to the internally fused "115VAC" terminals. Connect the signal from its source to the terminals marked "input" making sure to note the polarity if this is a D.C. signal source.* Low voltage signals or feedback signals from a drive system require using shielded cable to minimize noise interference. The shield should be connected to the meter common (+ input) with the other end floating and insulated.

*This unit has been tested for peak operational voltage isolation integrity between the input terminals and the input to case. We recommend, on input signals greater than 200 volts RMS, placing a 100K ohm 1/2 watt metal film resistor in series with each leg of the input signal wire. This is for the protection of the signal device in the event of a fault to ground or short within the meter itself.

Note: Before calibration, the meter should be powered for ten to fifteen minutes, to allow for warm up.

C) Calibration:

The range selection jumper is installed at the "D" position which will accommodate high input voltages. One of two methods is recommended to select the proper range and reading for your particular application.

Method I

If the maximum voltage to be applied to the signal input terminals is known and the desired readout is known, refer to the range selection table in **Figure 1** and install jumper (J1) to the correct terminal. Apply the maximum signal and adjust the coarse and fine potentiometers located on the back of the meter until the desired readout is obtained.

Method II

If the maximum voltage is not known leave the J1 jumper on the "D" range. Apply the maximum signal and adjust the coarse and fine potentiometers located on the back of the meter until the desired readout is obtained. (See **Figure 1**). If the desired readout cannot be reached, remove the signal input and move the J1 jumper down to range "C". Reapply the input signal and adjust the coarse and fine potentiometers to the desired readout. If necessary repeat the above for the next lower range scale until the desired readout is obtained.

Decimal point selection can be performed by adjusting the pin and jumper arrangement as shown in **Figure 3**.

This completes the installation and set-up procedures.

SERVICE NOTES

- A) A display of flashing zeros indicates an overscale reading and requires recalibration via the coarse and fine potentiometers and or a new range selection (refer to section C of "Installation & Calibration").
- B) The indicator installed, wired and powered with no signal input should read zero plus or minus a count. If this is not the case, remove the signal input leads and install a short jumper between the signal input terminals. Check for zero reading. If a zero is now displayed, a "noise signal" is being induced through the signal input cable. This can be corrected with shielded cable (see wiring notes page 2, section B). If a zero reading is still not obtained with the input shorted, adjust the offset potentiometer located on the face of the meter at the lower right hand corner. (See Figure 3).

Note: If the above procedures do not work please contact the factory.

- C) A display of "000" may indicate either reverse polarity or a zero input signal.
- D) The meter will accept an input signal voltage up to 10 times the rated value for a given range or 500 volts whichever is less. Example: range "B" is rated 5VDC/10VAC and will accept up to 50VDC or 100VAC.
- E) As with any piece of electronic equipment, care is recommended when handling and applying voltages. For further information or service contact the factory.

WARRANTY

R.T. Engineering Service, Inc. (RTE) warrants this equipment against defects in material or workmanship for a period of two years from the date of shipment. Material or workmanship defects within the first two years will be repaired or replaced at the option of RTE at no charge. Final determination of the actual defect rests with RTE.

This warranty does not apply to any product which has been misapplied, modified or subjected to misuse, negligence or accident. Any unauthorized repair, service or modification to this equipment voids the warranty.

The foregoing warranty is exclusive and in lieu of all other warranties expressed or implied including but not limited to any warranty of merchantability or fitness for a particular purpose. RTE is not liable for consequential damages of any kind.

Note: Any product found defective should be returned to RTE. The defective meter should be returned freight prepaid by the buyer to RTE.

FIGURE 1

DPM CONNECTION DIAGRAM

(REAR OF METER)

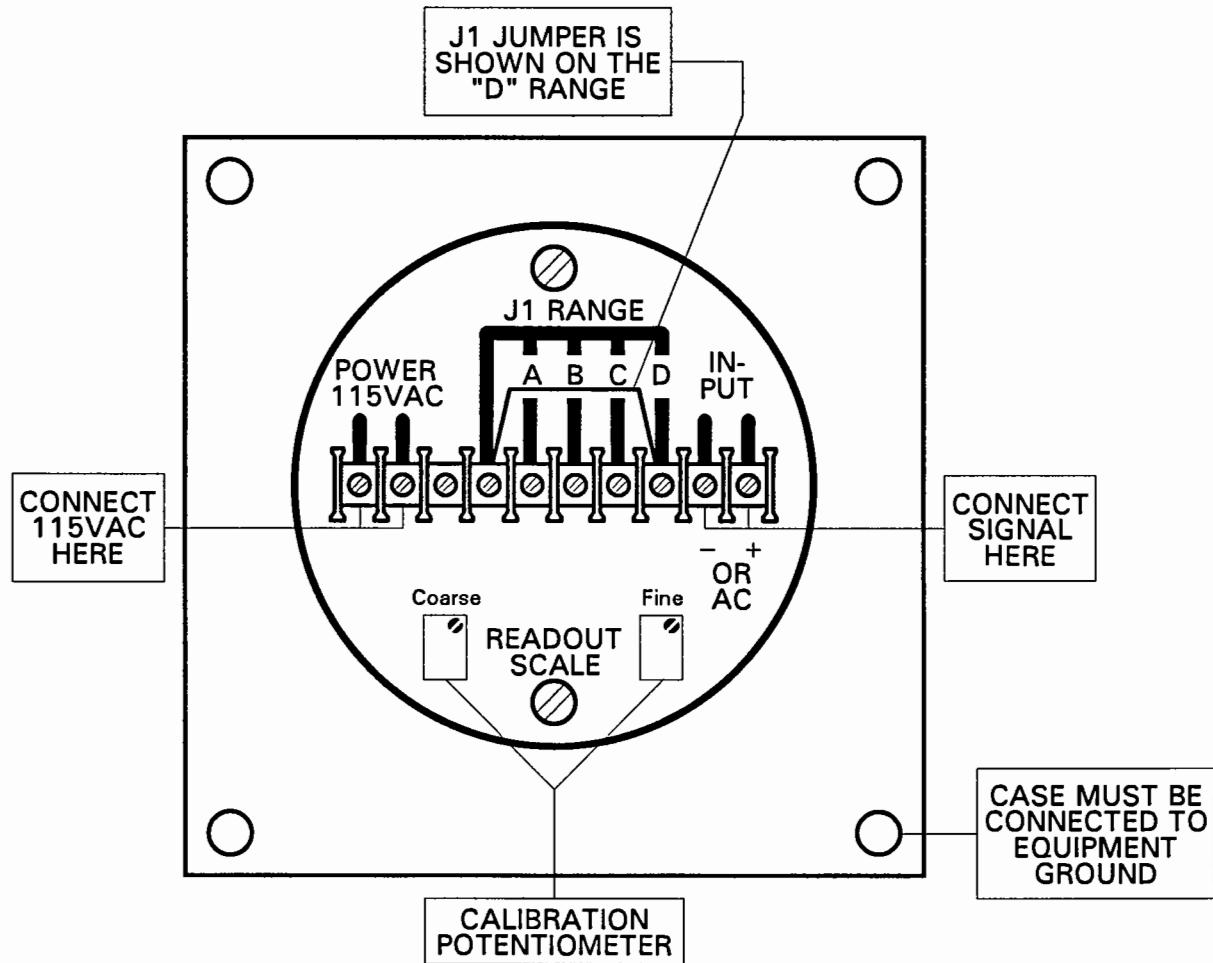

INPUT RANGES (J1) FOR FULL SCALE:

JUMPER CONNECTION	DC INPUT SIGNALS		AC INPUT SIGNALS	
	MINIMUM (1)	MAXIMUM	MINIMUM (1)	MAXIMUM
J1 TO A	50M VDC	500M VDC	100M VAC	1 VAC
J1 TO B	5 VDC	50 VDC	10 VAC	100 VAC
J1 TO C	50 VDC	500 VDC	100 VAC	480 VAC
J1 TO D	500 VDC	500 VDC	480 VAC	480 VAC

(1) These rated values represent minimum voltages necessary to read "19999" (Full Scale).

Maximum input voltage for each range is 10 times the rated value or 500 volts, whichever is less.

FIGURE 2

DPM STANDARD

4½" Case Size

(Dimensions in Parenthesis are in Millimeters.)

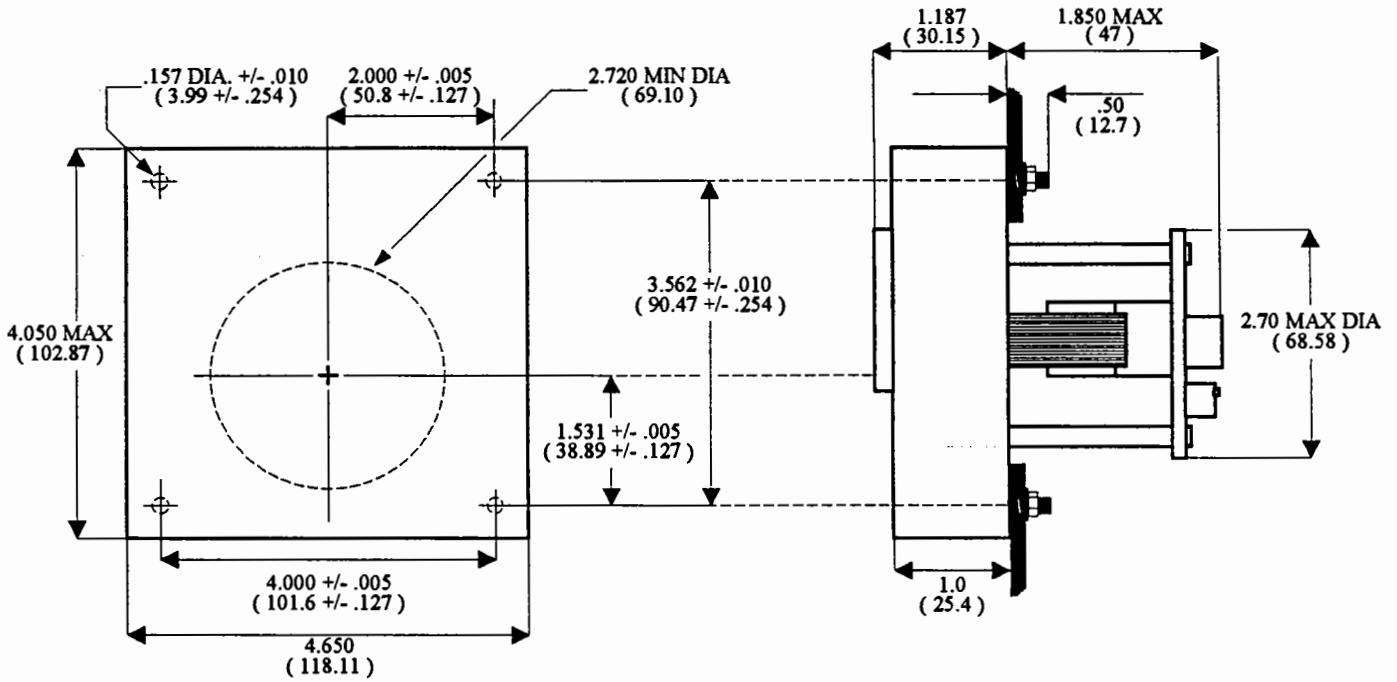
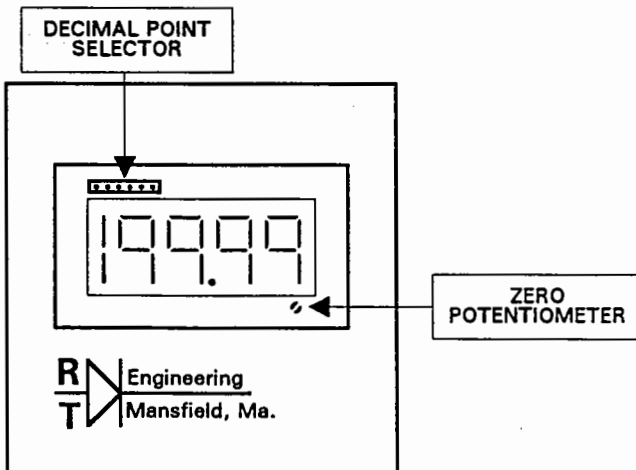

FIGURE 3

DPM45

Frontal layout & Decimal Position Selector



Decimal Select Pins

Positions	Display
● ● ● ● ■ ■ ■ ■	1888.8
● ● ● ■ ■ ■ ● ●	188.88
● ● ■ ■ ● ● ● ●	18888
● ■ ■ ■ ● ● ● ●	18.888
■ ■ ■ ■ ● ● ● ●	1.8888